

MLVS 0402 Series Engineering Specification

1. Scope

- (1) SMD type zinc oxide based ceramic chip
- (2) Lead free plating termination provided good solderability characteristic
- (3) Insulator over coat keeps excellent low and stable leakage current
- (4) Quick response time (<1ns)
- (5) Low clamping voltage
- (6) High transient current capability
- (7) Meet IEC 61000-4-2 standard
- (8) Compact size for ELA 0402

Applications

Applications for Mother Board and Notebook, Cellular Phone,PDA,handheld device, DSC,DV,Scanner,and Set-Top Box etc.

Suitable for Push-Button,Power Line and Low Frequency single line over voltage protect.

2. Explanation of Part Number

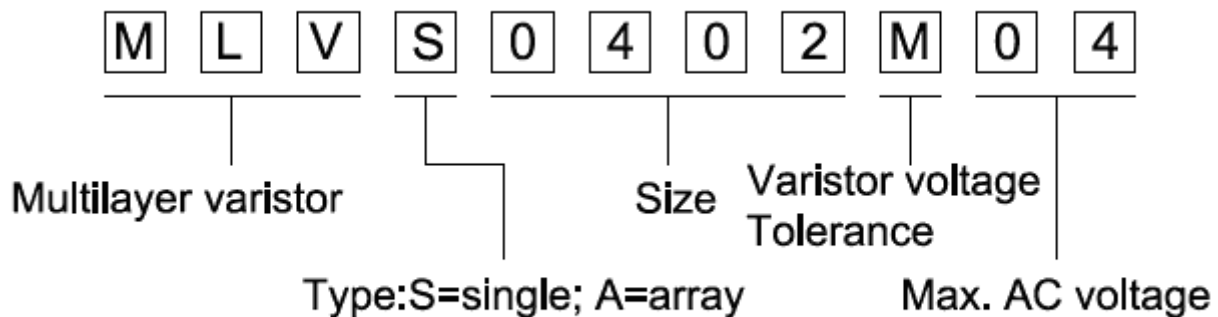

3. Construction & Dimension

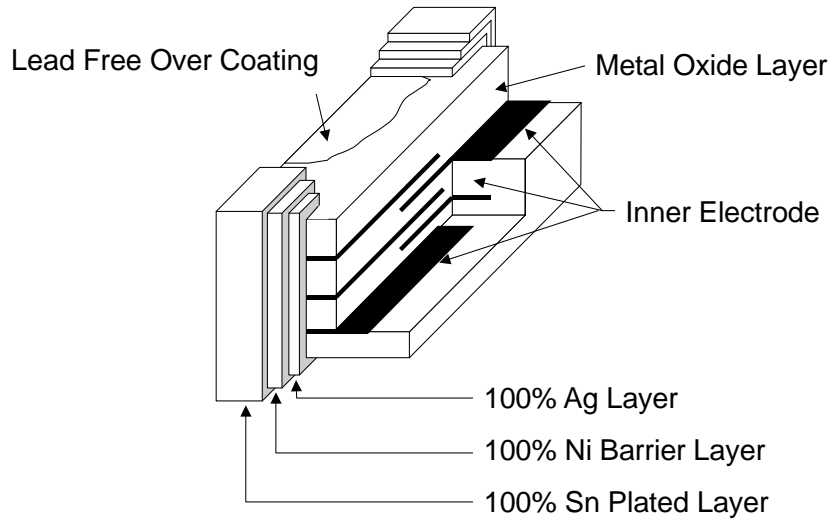
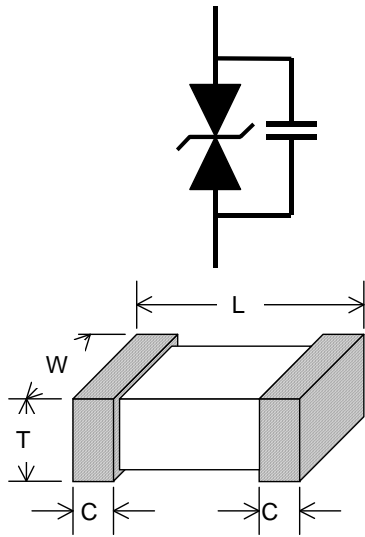

Unit: mm	0402
L	0.96±0.12
W	0.48±0.07
T	0.50±0.10
C	0.25±0.15

4. Part ratings and characteristics:

4.1. Rating(25±5°C)

Symbol	Working voltage		Varistor voltage		Clamping Voltage	Capacitance	Peak current	Transient energy
	V_{RMS}	V_{DC}	V_V	ΔV_V	V_C	C_p	i_{max}	W_{max}
Units	Volts	Volts (Max.)	Volts	%	Volts (Max.)	pF (Typical)	Amps (Max.)	Joules (Max.)
Test Condition		< 10 μA	1mA DC		1 A 8/20 μs	1MHz	8/20 μs	10/1000 μs
MLVS0402M04	4	5.5	8	±20	19	270	20	0.05
MLVS0402M07	7	9	12.5	±20	32	130	20	0.05
MLVS0402K11	11	14	18	±10	38	90	20	0.05

V_{RMS} – Maximum AC operating voltage the varistor can maintain and not exceed 10 μ A leakage current

V_{DC} – Maximum DC operating voltage the varistor can maintain and not exceed 10 μ A leakage current

V_V – Voltage across the device measured at 1mA DC current.
EquiValent to V_b , “Breakdown Voltage”.

V_c – Maximum peak voltage across the varistor measured at 8/20us waveform and 1A pulse current

C_p – Device capacitance measured with zero volt bias 1Vrms at 1MHz.
Capacitance Tolerance: M= \pm 20% , K= \pm 10%.

i_{max} – Maximum peak current which may be applied with 8/20us waveform without device failure

W_{max} – Maximum energy that may be dissipated with the 10/1000us waveform without device failure

5. General electrical specifications

5.1. General technical data

Operating temperature	-40 ... +85 $^{\circ}$ C
Storage temperature (on board)	-40... +85 $^{\circ}$ C
Response time	<1 ns
Solderability	245 \pm 5 $^{\circ}$ C, 3 \pm 1sec
Solder leach resistance	260 \pm 5 $^{\circ}$ C, 10 \pm 1sec

5.2. Environmental Specifications

Characteristics	Specifications	Test condition
Bias humidity	$\Delta V_V / V_V \leq \pm 10\%$	90%RH, 40 $^{\circ}$ C, Working voltage, 1000 hours
Thermal shock	$\Delta V_V / V_V \leq \pm 10\%$	-40 $^{\circ}$ C to 85 $^{\circ}$ C, 30 min. Cycle, 5 cycles
Full load voltage	$\Delta V_V / V_V \leq \pm 10\%$	Working voltage, 85 $^{\circ}$ C, 1000 hours

5.3. Storage Condition with package

Storage Time: 12 months max

Storage Temperature : 5 to 40 $^{\circ}$ C

Relative Humidity: to 65 %

6. Taping Package and Label Marking

6.1. Carrier tape dimensions

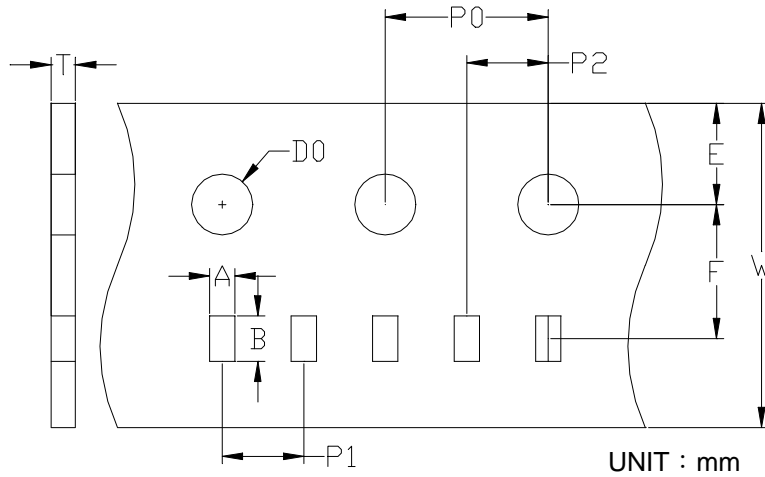

Type	A	B	W	E	F	P0	P1	P2	D0	T
0402	0.59 ±0.03	1.12 ±0.03	8.0 ±0.1	1.75 ±0.05	3.5 ±0.05	4.0 ±0.1	2.0 ±0.05	2.0 ±0.05	1.55 ±0.05	0.60 ±0.03

6.2. Taping reel dimensions

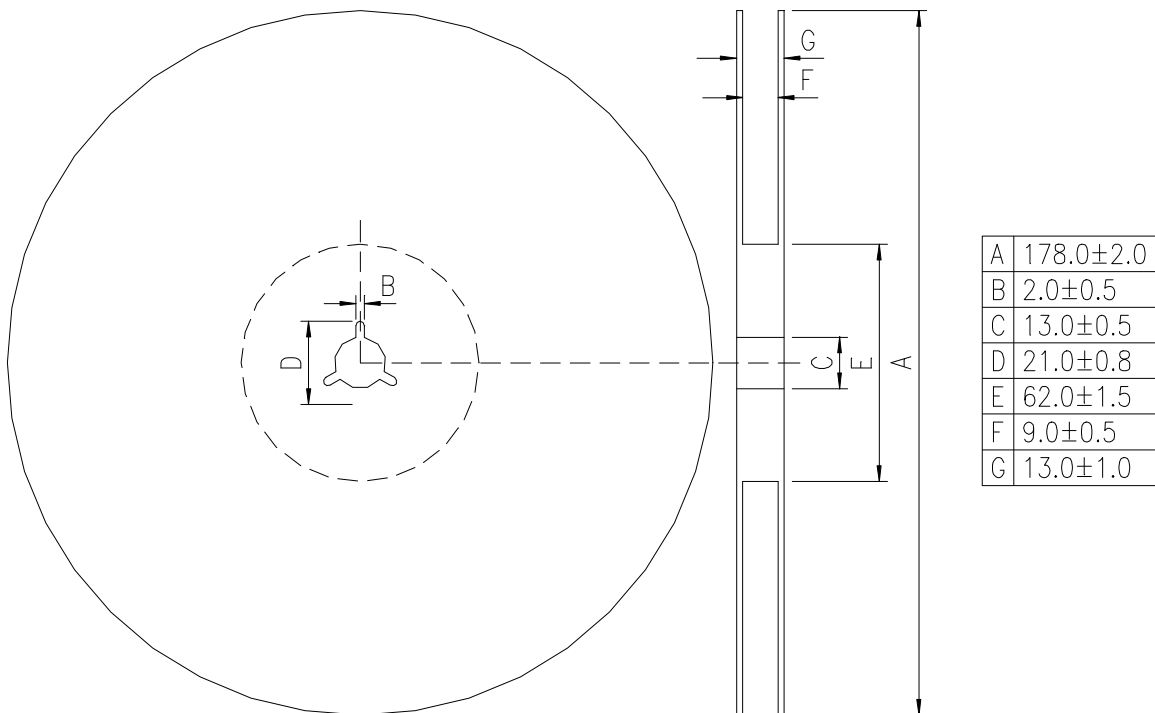

6.3 Taping specifications

There shall be the portion having no product in both the head and the end of taping, and there shall be the cover tape in the head of taping.

6.4 Label Marking

The label specified as follows shall be put on the side of reel.

- (1) Part No.
- (2) Quantity
- (3) Lot No.

*Part No. And Quantity shall be marked on outer packaging.

6.5 Quantity of products in the taping package

- (1) Standard quantity : 10,000pcs/Reel for MLVS-0402
- (2) Shipping quantity is a multiple of standard quantity.

7. Precautions for Handling

7.1. Solder cream in reflow soldering

Refer to the recommendable land pattern as printing mask pattern for solder cream.

- (1) Print solder in a thickness of 150 to 200 μm.
- (2) Dimensions: millimeters (inches)

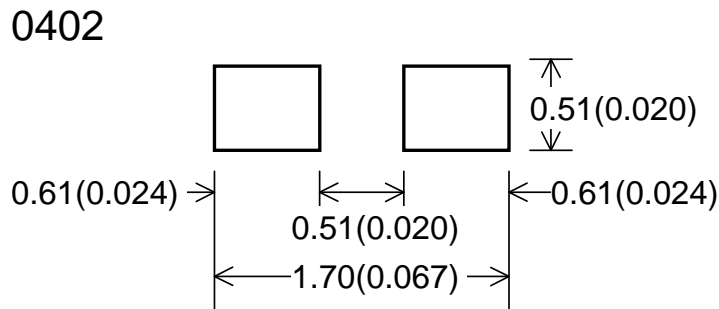

7.2. Precaution for handling of substrate

Do not exceed to bend the board after soldering this product extremely.

(Reference examples)

- Mounting place must be as far as possible from the position, which is close to the break line of board, or on the line of large holes of board.
- Do not bend extremely the board, in mounting another components.
If necessary, use back-up pin (support pin) to prevent from bending extremely.
- Do not break the board by hand. We recommend using the machine or the jig to break it.

7.3. Precaution for soldering

Note that rapid heating, rapid cooling or local heating will easily damage this product.

Do not give heat shock over 100°C in the process of soldering. We recommend taking preheating and gradual cooling.

7.4. Recommendable reflow soldering

Profile Feature	Pb-Free Assembly
Average Ramp-Up Rate (T _{smax} to T _p)	3° C/second max.
Preheat – Temperature Min (T _{smin}) – Temperature Max (T _{smax}) – Time (t _{smin} to t _{smax})	150 °C 200 °C 60-180 seconds
Time maintained above: – Temperature (T _L) – Time (t _L)	217 °C 60-150 seconds
Peak/Classification Temperature (T _p)	260 °C
Time within 5 °C of actual Peak Temperature (t _p)	20-40 seconds
Ramp-Down Rate	6 °C/second max.
Time 25 °C to Peak Temperature	8 minutes max.

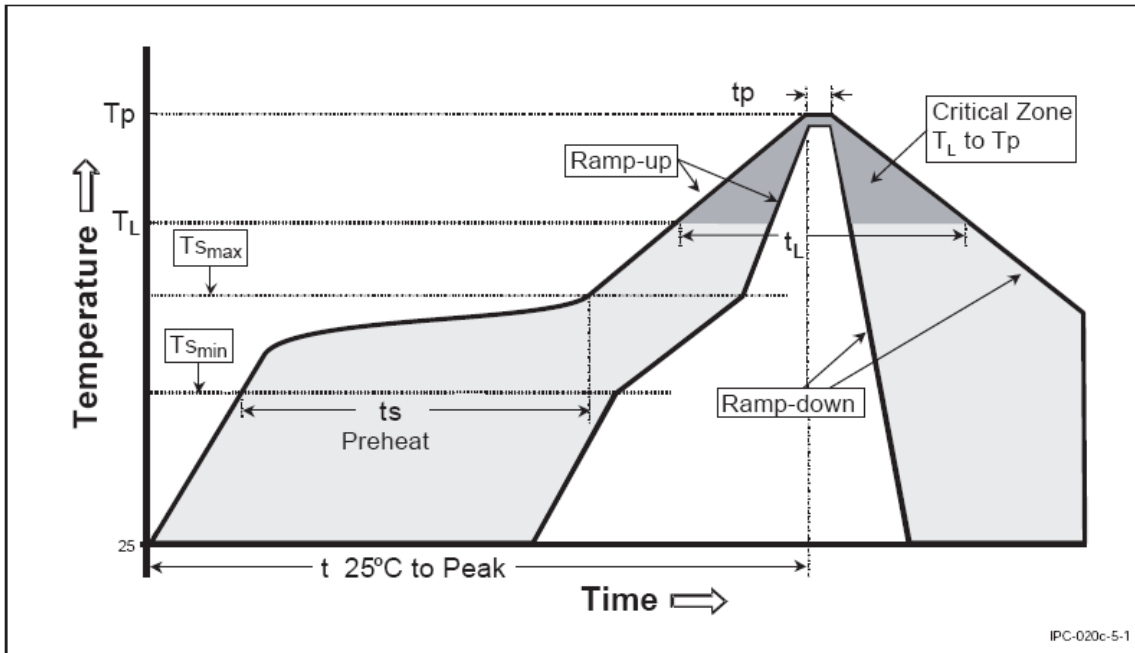

*According to J-STD-020C

7.5. Soldering gun procedure

Note the follows, in case of using solder gun for replacement.

- (1) The tip temperature must be less than 280°C for the period within 3 seconds by using soldering gun less than 30 W.
- (2) The soldering gun tip shall not touch this product directly.

7.6. Soldering volume

Note that excess of soldering volume will easily get crack the body of this product.